

FIGURE 7. TEMPERATURE RESISTIVITY CURVE FOR MANGANIN WIRE

The transducer cap was made of a 6-percent-cobalt grade of tungsten carbide having the following approximate properties:

Specific Gravity	14.9
Hardness	90 R _A
Young's Modulus	80 x 10 ⁶ psi
Compressive Strength	700 x 10 ³ psi
Tensile Strength	200 x 10 ³ psi
Transverse Rupture Strength	250 x 10 ³ psi
Poisson's Ratio	0.2
Thermal Conductivity	50.0 Btu/hr/ft/F
Thermal Expansion	2.5 x 10 ⁻⁶ in./in./F.

Proportions of the cap were determined in part by the space required to locate the strain gages on the cylindrical bore and also by the design requirement that the maximum compressive stress in the cap should not exceed two thirds of the compressive strength of the material at the operating pressure of 250 ksi. A tight seal between the cap and stem was obtained by lapping the two together. This prevented the high-pressure fluid from leaking from the pressure chamber into the lead wire hole.

A four-arm strain-gage bridge was used in the cap with two "active" and two "temperature-compensating" gages. The two active gages were placed close to the juncture between the cylindrical and the hemispherical bores. The two temperature-compensating gages were placed on a thin wafer of tungsten carbide which in turn was placed in contact with the top of the hemispherical bore. These two gages were stress free. Then the bore was potted with a high-temperature silicon rubber up to depth of the bushing. The bushing which is used to hold the cap on the stem was then shrink

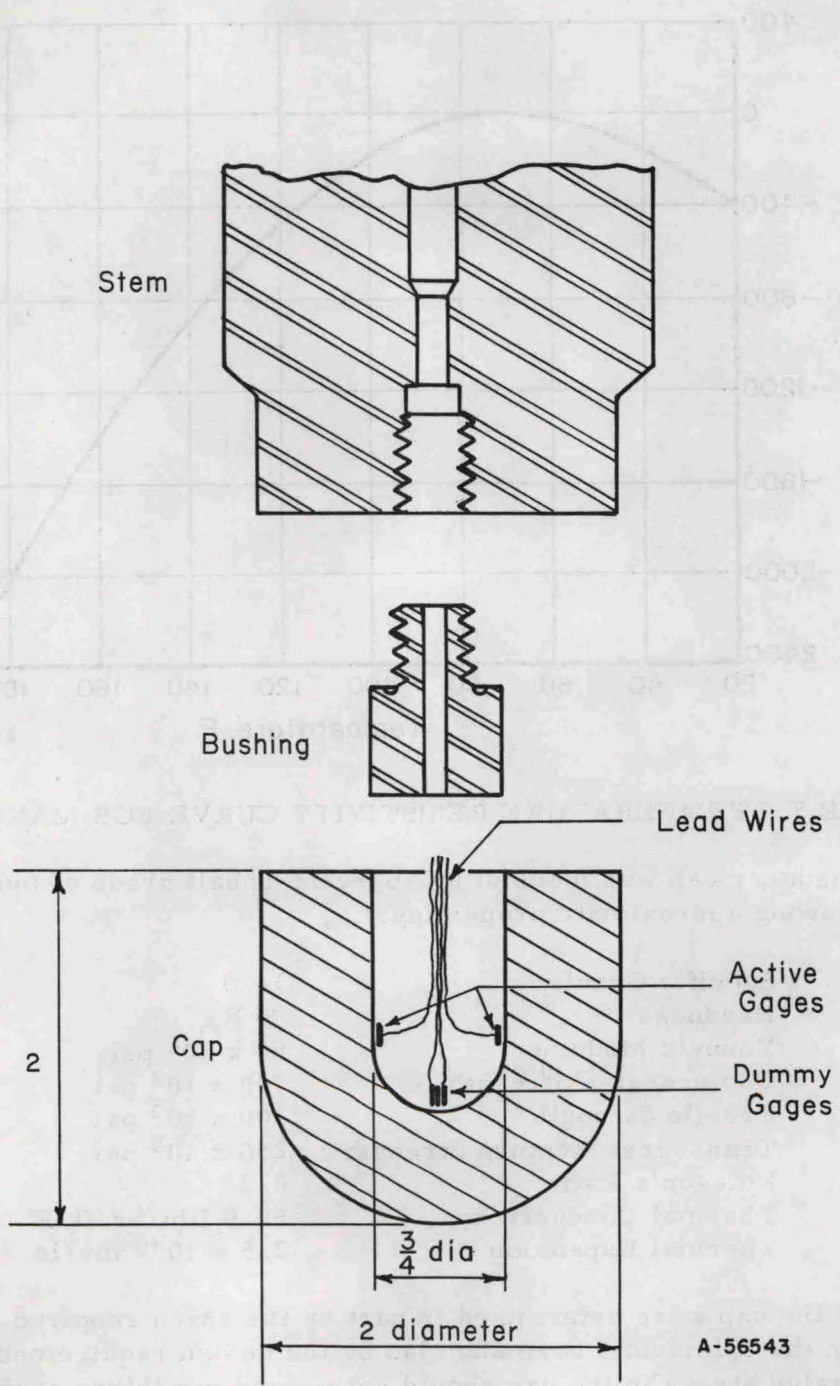

FIGURE 8. HIGH-PRESSURE TRANSDUCER DEVELOPED AT BATTELLE FOR MEASURING HIGH FLUID PRESSURES AT ROOM AND ELEVATED TEMPERATURES

All dimensions given in inches.